

# Camden Fold Slide Systems

## 70MM THERMALLY BROKEN ALUMINIUM BI-FOLD DOORS

### Camden Fold 'N' Slide Features and Applications

#### Aluminium...

Aluminium offers a contemporary, modern look coupled with strength, durability and low maintenance. Aluminium retains thermal efficiency and eliminates condensation. The hardwearing finish of the door makes it ideal for domestic and commercial properties.

#### Security...

The door is fitted with high security locking systems and an inline, out-of-sight track system. The running gear is encapsulated and concealed within the track so that the door cannot be lifted off its tracks. The locking system also features hardened steel hook locks, dead bolts and top/bottom shoot bolts. All folding mechanisms are fitted with high security hinges.

#### Styles...

There are a range of opening styles including: inward and outward opening, folding to the left and folding to the right.

#### Weather Resistance...

The door has been tested at a UKAS accredited testing station and has achieved PAS 23 weather testing to extreme weather conditions of over 300 pascals. The bifold also features high performance rubber seals and brush seals for weather tightness.

**With no fixed panels or posts, the Camden Fold N Slide Door features a number of door leaf options which roll easily on a track and fold in on themselves, creating a full and open space. Suitable for domestic or commercial applications to replace existing doors or other unused spaces.**



Extensions



Windows



Conservatories



Balconies



Room Dividers

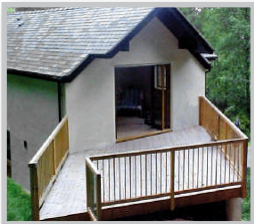

Patios



Swimming Pools



Commercial



Stores & Restaurants



Corners

**We manufacture a quality door that features a zero threshold, no locking mullions or sliding posts and top/bottom adjustable rollers...**

- Value engineering giving us the strongest system on the market
- Accredited with PAS 23 & PAS 2
- CE & CPD Compliant and ISO 9001 certified
- 15 year manufacturer warranty to end user
- Manufactured up to 4m high & 8m wide
- Suitable for commercial & domestic use

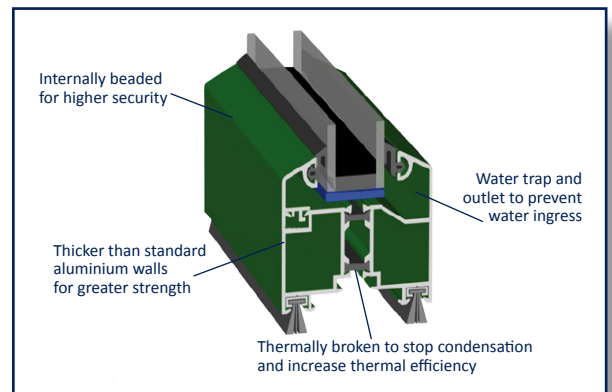

CAMDEN  
GROUP

4-7 Steeple Industrial Estate, Antrim, Co. Antrim, Northern Ireland, BT41 1AB

UK Tel: 028 9446 2419 UK Fax: 028 9442 8138

ROI Tel: 048 9446 2419 ROI Fax: 028 9446 4002

Web: [www.camdengroup.co.uk](http://www.camdengroup.co.uk) Email: [info@camdengroup.co.uk](mailto:info@camdengroup.co.uk)

# Camden Fold Slide Systems

## 70MM THERMALLY BROKEN ALUMINIUM